

S4420/27-__O

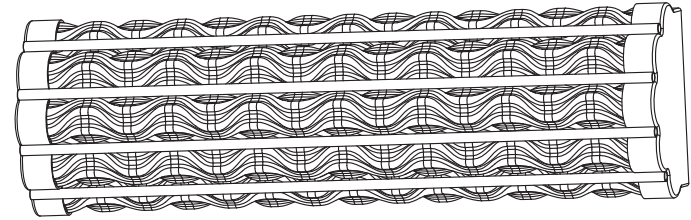

THIS DESIGN IS THE PROPRIETARY
TRADE DRESS/TRADEMARK OF
W SCHONBEK LLC.

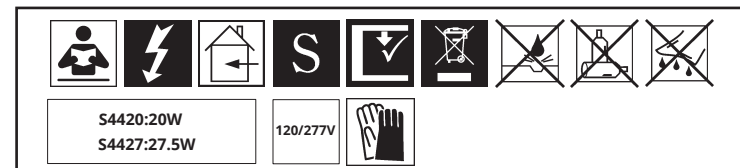

WWW.SCHONBEK.COM/INSTALLATIONMANUAL

All electrical components must be installed by a licensed electrician in accordance with the National Electric Code and the appropriate local electrical codes.

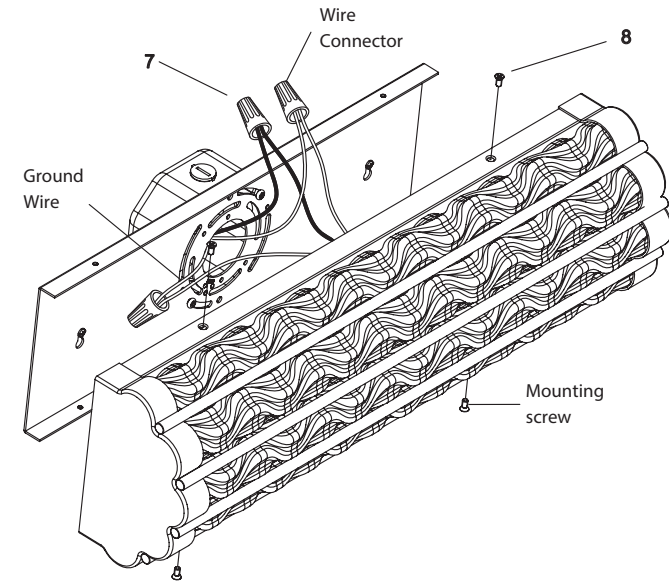
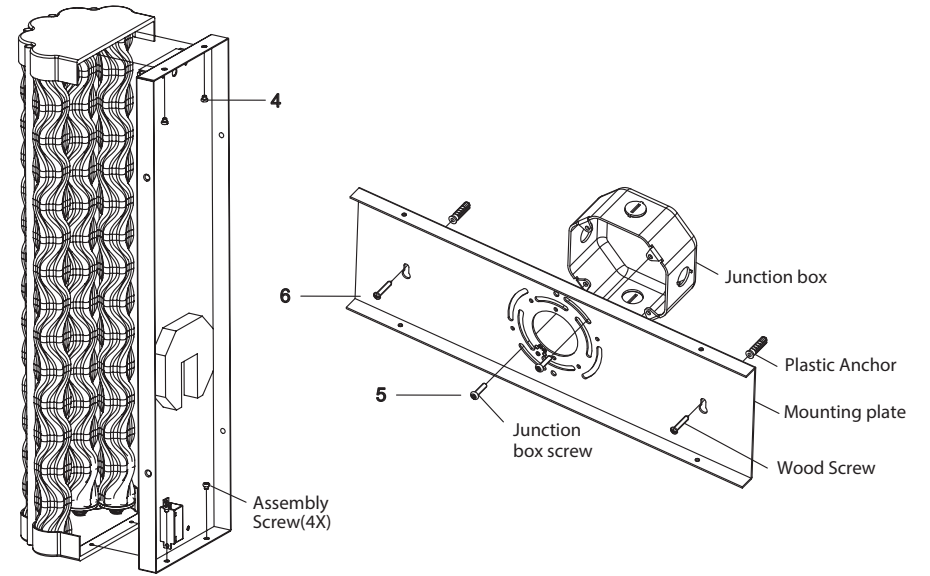
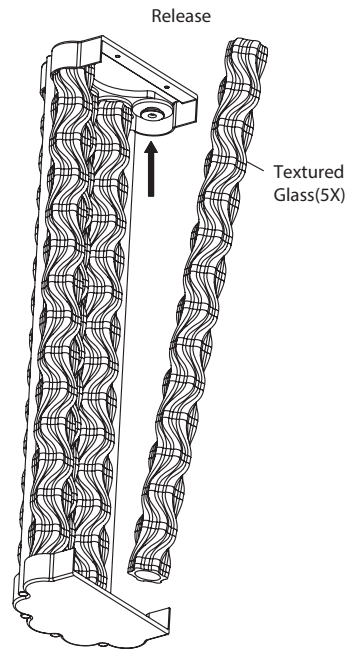
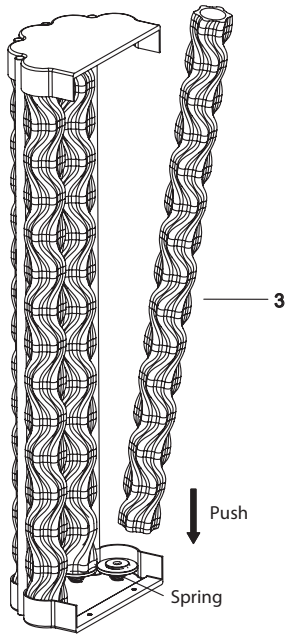
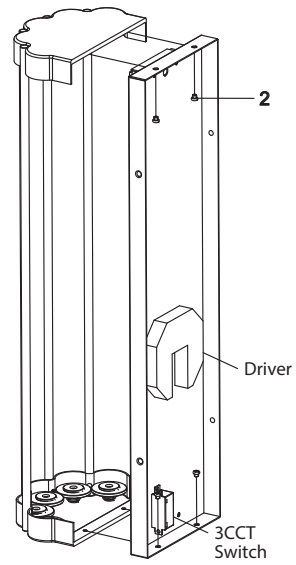
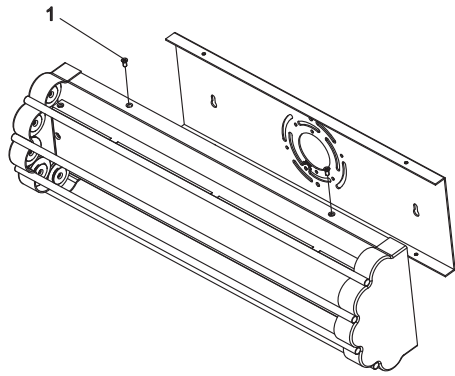

本页仅用于版本控制，请勿印刷！

序号	变更说明	变更人	变更日期
1			
2			
3			
4			
5			